

GV 17S 203 LS

Part No.: 5170000

- Load Sense¹

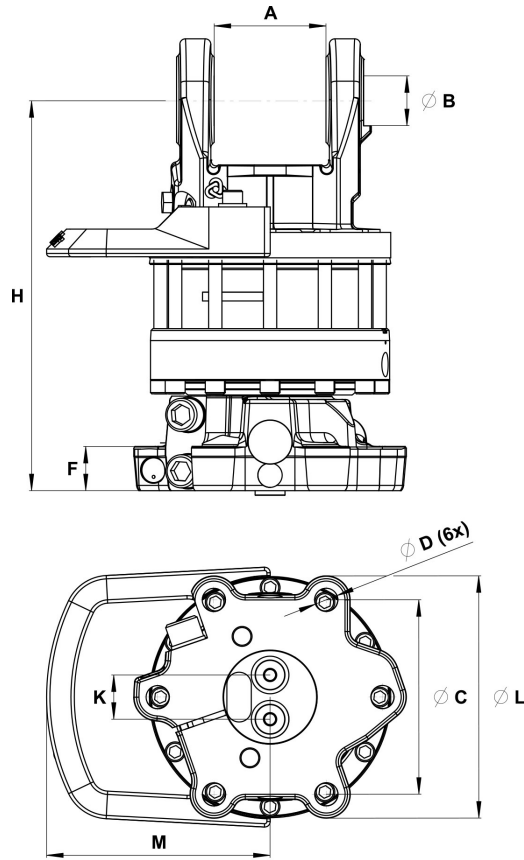
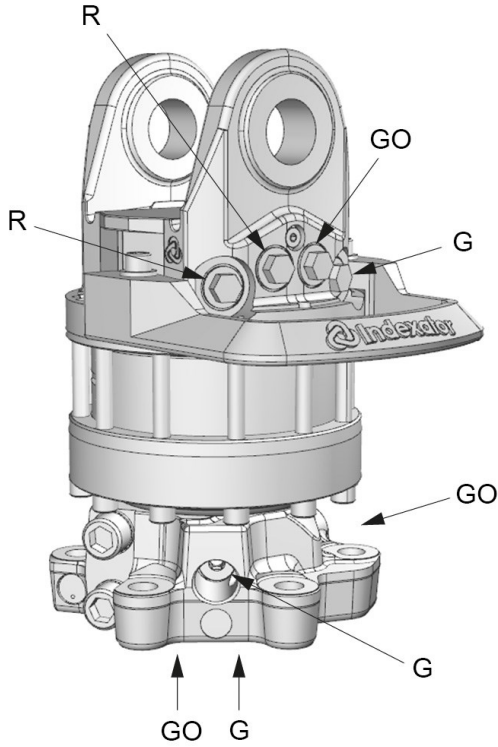

Upper connection	Lower connection
G 1/2	G 1/2

A: 101 mm	B: Ø45 mm	C: Ø203 mm	D: Ø21 mm	F: 40 mm	H: 353 mm	K: 40 mm	L: Ø248 mm	M: 202 mm
--------------	--------------	---------------	--------------	-------------	--------------	-------------	---------------	--------------

		Max 	Max 		Max 	Max 	Max 	Max
63.8 kg	360°	160 kN	50 kN	3300 Nm	25 l/min	25 MPa	25 MPa	25 MPa

¹ A rotator with the shortening LS is not equipped with restrictors (unlike our standard rotators). This means that the oil flow from the base machine has to be adapted.

Adapter sets are available for alternative connections.

For further technical information relating to integration and hydraulic connections, please contact rotator@indexator.com