

GV 124 M16

Part No.: 5112139

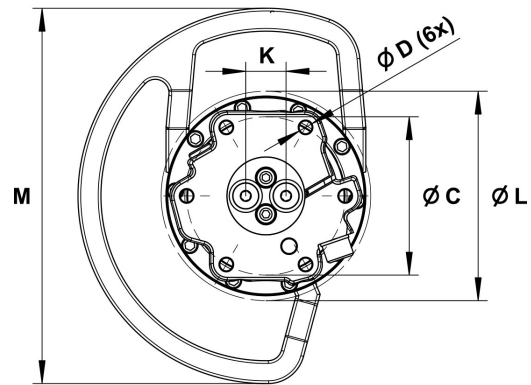
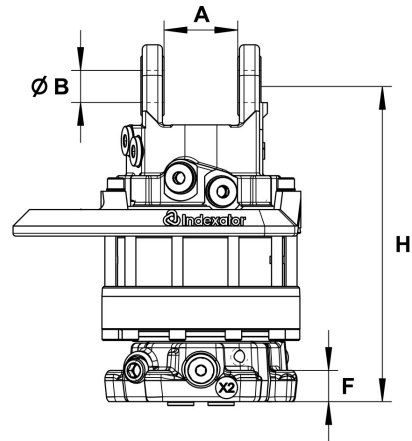
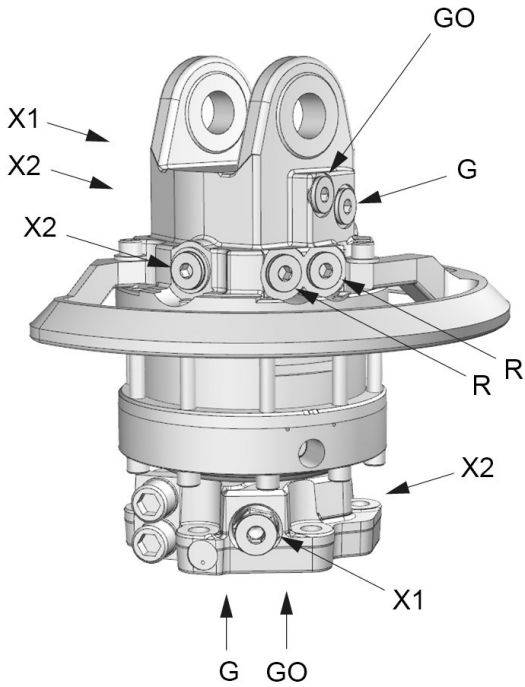

Upper connection	Lower connection	Upper		Lower	
G 1/2	G 3/4	X1: G 3/4	X2: G 3/4	X1: G 3/4	X2: G 3/4

A: 80,5 mm	B: Ø35 mm	C: Ø173 mm	D: M16	F: 30 mm	H: 345 mm	K: 44 mm	L: Ø229 mm	M: 410 mm
---------------	--------------	---------------	-----------	-------------	--------------	-------------	---------------	--------------

		Max 	Max 		Max 	Max 	Max 	Max 	Max 	Max
56.6 kg	360°	100 kN	50 kN	2200 Nm	25 l/min	25 MPa	20 MPa	25 MPa	25 MPa	25 MPa

Rotator with two extra connections for e.g. a grapple saw.

Adapter sets are available for alternative connections.

For further technical information relating to integration and hydraulic connections, please contact rotator@indexator.com